

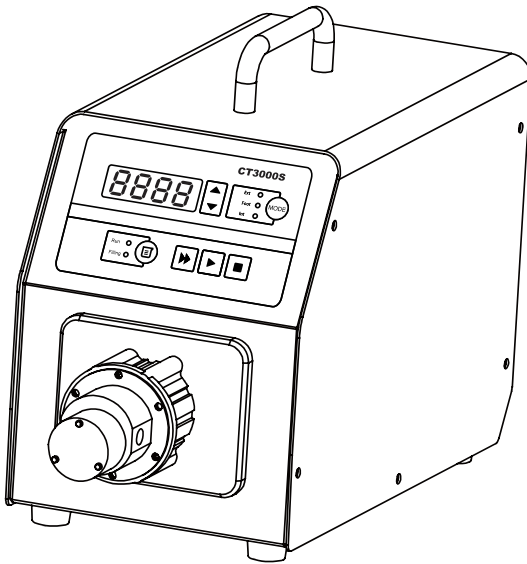

GOLANDER PUMP

CT3000S Variable-Speed Gear Pump

Operation Manual



info@golanderpump.com

<http://golanderpump.com>

1-678-587-8806

Contents

Safety Cautions	1
1 Introduction.....	2
2 Functions and Features.....	2
3 Specifications	3
4 Components and Connectors.....	4
5 Display Panel and Operating Keypads.....	5
5.1 Keypad	5
5.2 Digital LED and Indicators.....	6
6 External Control Interface.....	7
7 Operation Instructions	8
7.1 Before Operating.....	8
7.2 Power Connection.....	8
7.3 Install pump head and tubing.....	8
7.4 Working Mode	10
7.5 Internal Control Mode.....	10
7.6 External Control Mode	11
7.7 Time Dispense Mode	13
7.8 Logic Level Control Mode	14
7.9 Communication Mode	15
7.10 Footswitch Control	16
8 Maintenance.....	18
8.1 Warranty.....	18
8.2 Regular Maintenance	18
8.3 Malfunction Solutions	18
9 Dimensions.....	20
10 Naming Rule.....	20
11 Suitable Pump Heads.....	20

Safety Cautions



Danger: Please use the correct AC power voltage source shown on the sticker attached on the equipment to avoid any damage. Please do not open the case. It may cause malfunction or electric shock.

For maintenance, please contact the manufacturer or distributor directly.

Danger: To install or remove pump head, please turn off the power supply first. The flange of the pump head must be handled carefully. Please do not use pliers to clamp it. It may cause inner core displacement, or even permanent damage of the pump.



Warning: Tubing breakage may result in fluid being spayed from pump. Use appropriate measures to protect operator and equipment.

Warning: Remove power from the pump before attempting any maintenance or any cleaning operation is started.

Warning: Remove power from the pump before connecting or disconnecting the external control device or communication interface.

Warning: The pump is provided with a grounded plug, it must be well-grounded at all times.

Warning: This product is not designed for, nor intended for use in patient connected applications; including, but not limited to, medical and dental use.

Warning: Avoid any foreign bodies, including sealant or Teflon tape if they are used to seal the tubing, to get into the pump. Only remove the two covers on the pump head when installing connector or tubing,

Warning: It is strongly recommended that when using the pump, especially for the entrance, tubing size should be corresponding to the competency of pump to avoid cavitation, which are caused by inadequate fluid for abnormal wear. In any case the pressure between the inlet and outlet shall not exceed 20 bar / 290 psi.

Warning: it is strongly recommended to add a filter to the inlet of the pump to filter out the particles bigger than 10 um, to avoid the internal components to wear and tear abnormally. The filter surface area should

be large enough to avoid pressure loss in the loop. It is also important to regularly check the filter to make sure it works effectively. If a vacuum gauge is installed after the filter, when the vacuum increases more than 0.1 bar, the filter needs to be cleaned or replaced.

Warning: The gear pump can only transfer liquid in one direction.

1 Introduction

CT3000S is a high performance and low noise micro gear pump. The brushless motor with stainless steel magnetic drive pump head can transfer fluid continuously and smoothly without pulsation. It has a stainless steel case for the drive, 4-digit LED display for motor speed and indicators for working status. It's suitable for various lab use. With standard MODBUS RS485 interface, the pump is easy to be controlled by external device, such as computer, human machine interface or PLC.

CT3000S provides speed range from 300 to 3000 rpm, with 1 rpm resolution.

2 Functions and Features

- Work with variable pump heads
- Suitable for high viscous and pressure liquid transfer
- No pulse, low noise
- Magnetic coupling drive, easy to maintain
- Brushless drive, high efficiency, maintenance free
- LED display, with buttons
- Display and control motor rotating speed
- Time dispense
- External signal controls start/stop/dispensing; external analog signal adjusts speed
- RS485 MODBUS interface
- Stainless steel case
- Switching power supply, 85~260VAC/50~60Hz

3 Specifications

Pump Head	MS204, MS209, MS213 (PEEK gear material)
Communication	RS485, support Modbus communication protocol
Display	LED display for motor speed; Indicators for working mode
Flow Range	90-2700 mL/min
Speed Range	300-3000 rpm
Speed Resolution	1rpm, speed accuracy 3%
Liquid Viscosity	≤200cSt
Particle Size	≤10um
Operation	Keypad and touch screen
Control Mode	Flow Mode, Time Dispense
External Control	5V (12V/24V optional) to control Start/Stop
	0-5V (0-10V,4-20mA optional) to control speed
Power Supply	AC 90-264V 50Hz/60Hz
Consumption	<150W
Working Environment	Temperature 0 -40°C, humidity <80%
Dimensions (LxWxH)	320x150x237mm (12.6x5.9x9.3inch)
Drive Weight	5.5kg (12.1lbs)
IP Standard	IP31

4 Components and Connectors

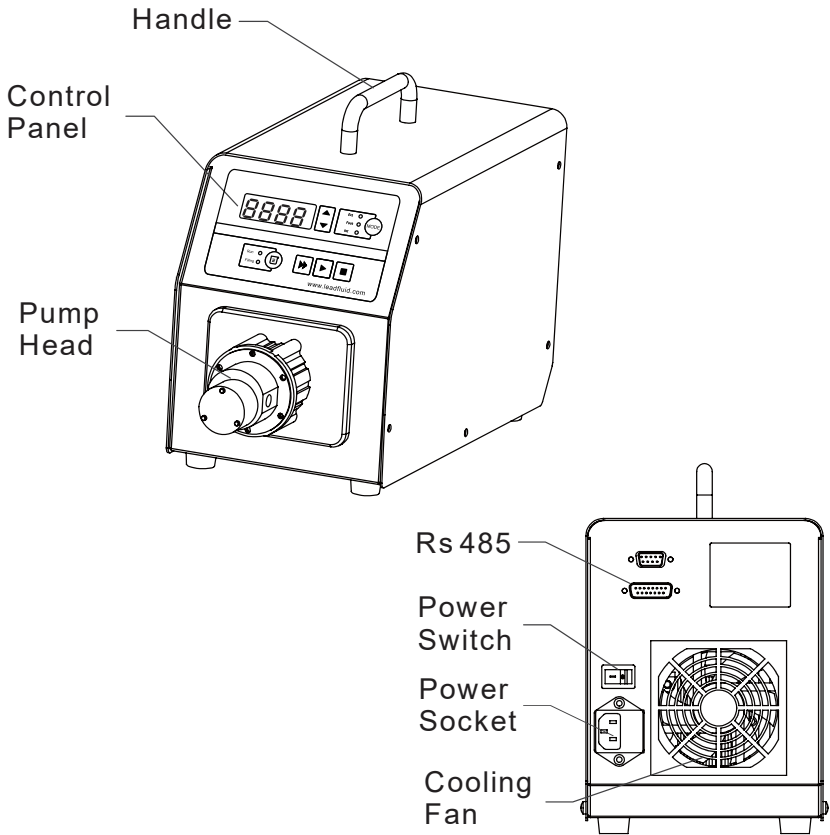

Figure 1. Components and Connectors

5 Display Panel and Operating Keypads

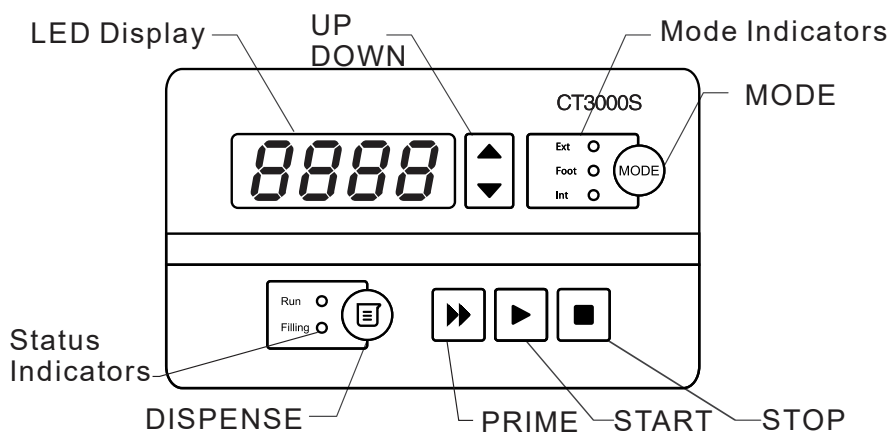
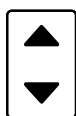

Figure 2. Display Panel

5.1 Keypad



UP key: To increase the speed. When press UP key shortly, the last digit of speed will increase 1. Hold the key to increase speed quickly.

DOWN Key: To decrease the speed. When press DOWN key shortly, the last digit of speed will decrease 1. Hold the key to decrease speed quickly.



START key. To start drive.



STOP key. To stop the drive.



MODE key. To change the working mode. Switch the working mode to External control, Footswitch control or Internal (keypad) control when the drive is not running.



DISPENSE key. To start Time Dispense Mode when the drive is not running. Press and hold the DISPENSE key to start Time Dispense Setup Mode.



PRIME key. Press the key to run pump at maximum. Press again to return to the previous state.

5.2 Digital LED and Indicators

5.2.1 Indicators

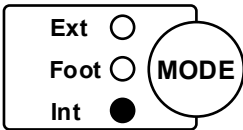

Int: Internal Control Mode. Use the keypad to operate the pump. Footswitch can be used to control start /stop.

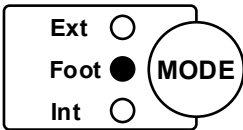

Foot: Time Dispense Mode. Use footswitch or DISPENSE key to start or stop dispensing. Use the keypad for other operations.

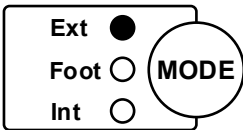

Ext: External Control Mode. Use external analog signal to control rotating speed. Use logic level signal to control start and stop. The keypad is disabled.

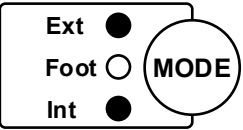

Int+Ext: Logic Level Control Mode. Use logic level signal to control start and stop. Use the keypad to control speed.

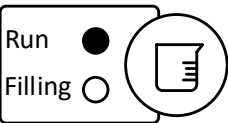

Drive is running.

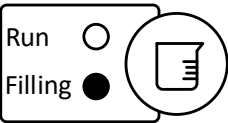

Working on dispense mode.

5.2.2 Digital LED Display

The digital LED displays the rotating speed and working mode.



Figure 3. Internal Control Mode, 1215 rpm

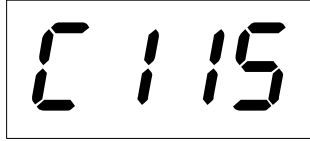

Figure 4. Time Dispense Mode, Dispense time: 115 seconds

When flashing, pump is on Time Dispense Setup Mode



Figure 5. Drive is running at full speed

6 External Control Interface

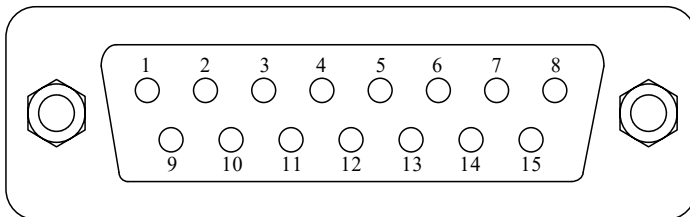

DB15	Mark	Note
1	ADC_W	Positive of external analog input
2	B	Communication interface, B pole of RS485

3	A	Communication interface, A pole of RS485
4	VCC_W	External DC power input
5		
6		
7		
8	COM	Ground of external power
9	AGND	Negative of analog signal input
10	+12V	Positive of internal +12V power source
11	GND	Ground of Internal power source
12		
13	RS_W	External start/stop signal input
14		
15	RS	Start/stop signal output

7 Operation Instructions

7.1 Before Operating

- 1) Please check the packing slip to make sure nothing is wrong or damaged in the package. If there is problem, please contact the manufacturer or distributor.
- 2) Read through the instruction.
- 3) There should be more than 200 mm space for the back of the pump when it is running.

7.2 Power Connection

The voltage of the power supply should be marked on the sticker of the drive. Please make sure to use the right power source for the drive. Plug the power cord into the power connector on the rear of the pump and plug the opposite end of the power cord into an electrical outlet. Flip the power switch located on the rear of the pump.

7.3 Install pump head and tubing

7.3.1 Install pump head

- 1) Put the pump head into the pump head holder, keep the entrance

horizontal.

- 2) Align the pump head and bracket mounting holes. Use provided M3x8 mm stainless steel screws and nuts to tighten pump head on the bracket.

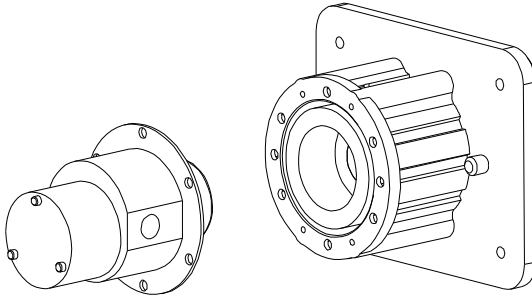

Figure 6. Install Pump Head

7.3.2 Install tubing

- 1) Screw 1/8NPT threaded stainless steel or plastic joints on the pump head. Please pay attention that the internal and external thread is in good shape and there's no residue left.



Good

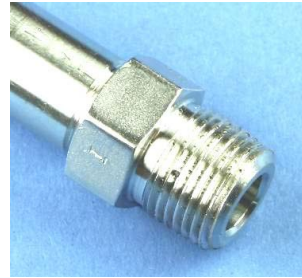

Defective

- 2) Wrap two layers Teflon tape clockwise on the threads. Make sure there will be no tape entering the inner part of the pump.



- 3) Tighten the nut with a torque wrench on the pump. Please note don't use excessive force to strip the threads.

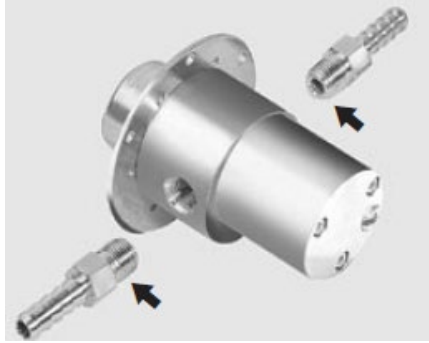

7.4 Working Mode

To change the working mode, turn on the power switch. The display will be on. Press MODE key to change the working mode.

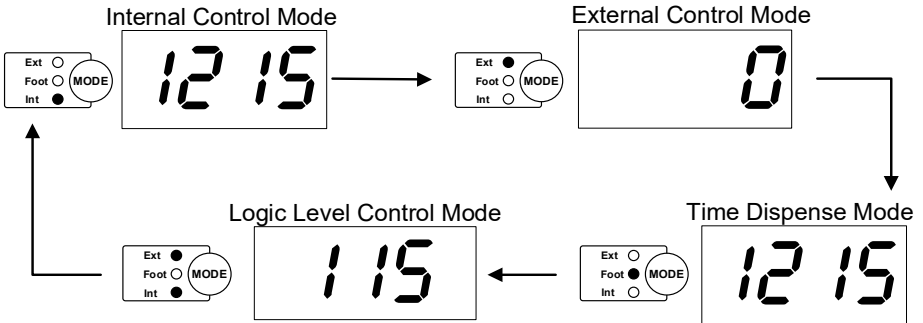
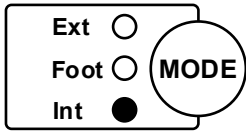

Figure 7. Change Working Mode

7.5 Internal Control Mode

On this mode, use the keypad to operate the pump.

- 1) Turn on the power switch. The display will be on.



- 2) Press MODE key to change the mode to Internal Control Mode.
- 3) Press UP or DOWN key to set the speed.
- 4) Press RUN or STOP key to start/stop the drive.

- 5) Press PRIME key to run the drive at full speed.

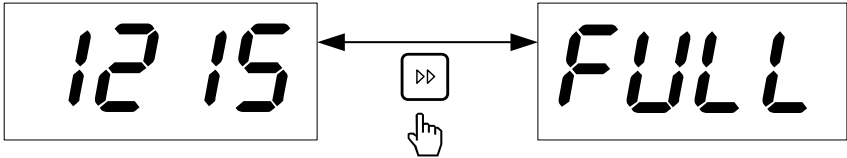

Figure 8. Full Speed

7.6 External Control Mode

On this mode, use logic level signal to control start and stop, and use external analog signal to control rotation speed. The keypad is disabled. The analog signal could be 0-5V, 0-10V or 4-20mA. By default, the signal is 0-5V. For 0-10V or 4-20mA, the jump setting on the analog signal control board has to be changed.

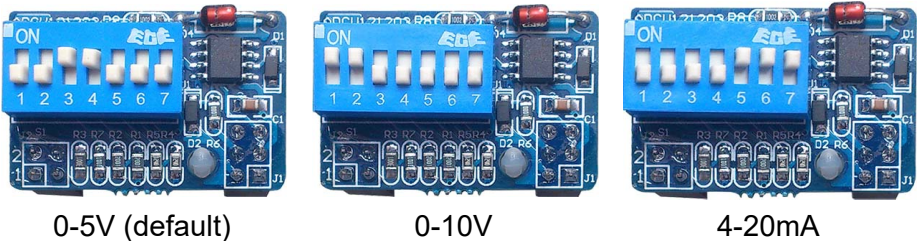

Figure 9. Analog Signal Control Board Setting

To control pump by external signal

- 1) Switch the power off. Wire the DB15 connector as shown on [Figure 10](#) or [Figure 11](#), and connect it to the DB15 port on the rear of the pump.

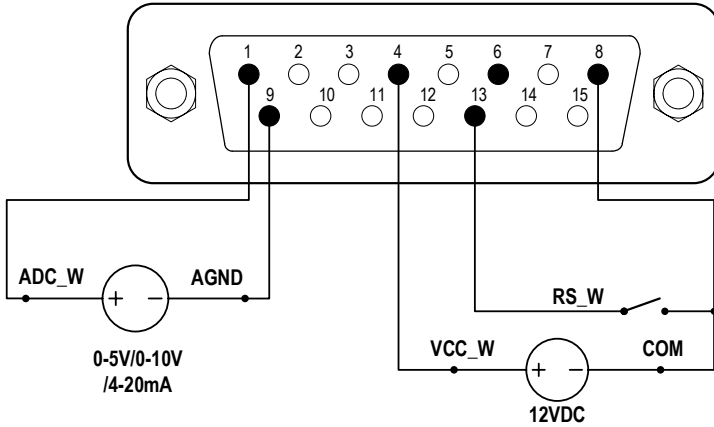

Figure 10. DB15 Wiring with External 12VDC Power Source

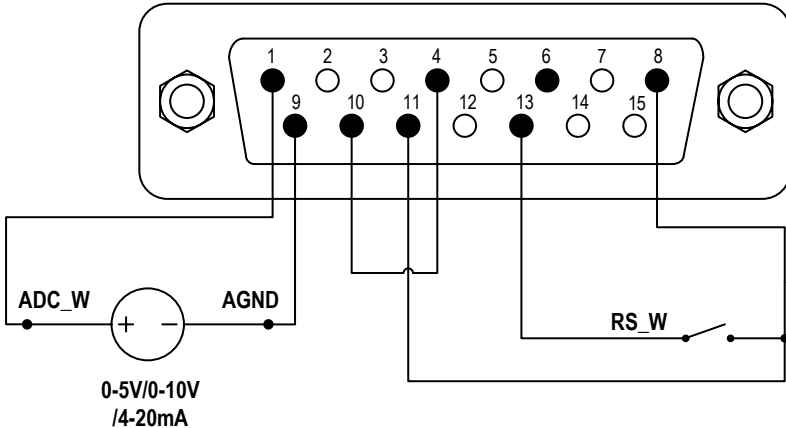
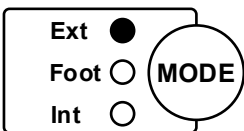

Figure 11. DB15 Wiring with Internal 12VDC Power Source

2) Turn on the power switch. The LED display will be on.



3) Press MODE key to change the mode to External Control Mode.

4) Close the external RS_W switch, and turn on the external analog signal power source. The speed will change according to the intensity of the input signal. Open the RS_W to stop the drive.

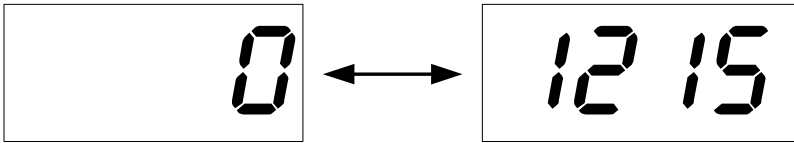

Drive Stopped

Drive Running

Figure 12. External Control Mode

Note: The external DC power source can be 5V, 12V. If it is 24V, 1.5K resistor is needed to protect internal circuit.

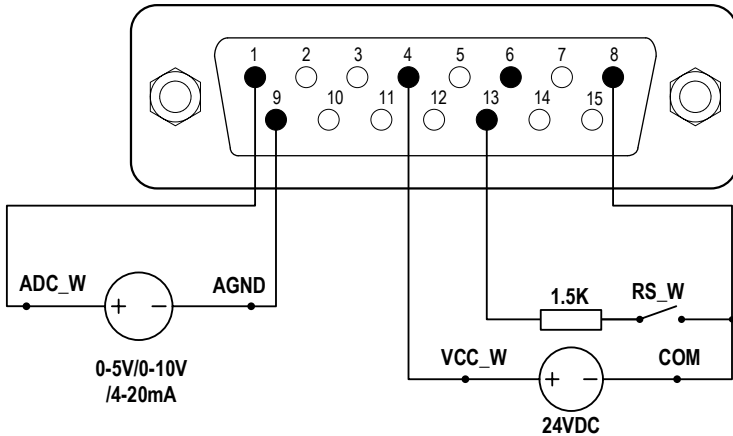

Figure 13. DB15 Wiring with External 24VDC Power Source

7.7 Time Dispense Mode

On this mode, the pump will dispense liquid by time for each dose. The drive will stop when finished running for the set time.

To set the dispense duration for each dose

- 1) Turn on the power switch. The display will be on.

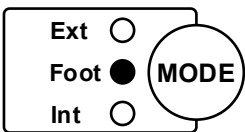

- 2) Press MODE key to change the mode to Time Dispense Mode or Internal Control Mode.
- 3) Press and hold DISPENSE key for 3 seconds, the digital LED display will be flashing.

Then pump is on Time Dispense Setup Mode.

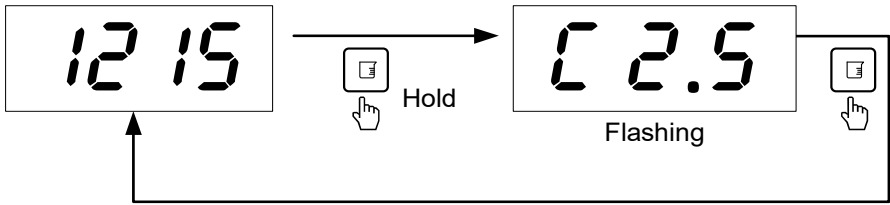

Figure 14. Time Dispense Setup Mode

- 4) When on Time Dispense Setup Mode, use UP/DOWN key to change the dispense duration. The time could be from 0.1 to 999 seconds.
- 5) Press the DISPENSE key again to exit the Time Dispense Setup Mode.

To Dispense Liquid

- 1) When on Internal Control Mode or Time Dispense Mode, press DISPENSE key to dispense one dose. Press DISPENSE key again to repeat dispensing.
- 2) When on Time Dispense mode, an optional footswitch can be used to start dispensing. Close then open the footswitch to dispense one dose. Close then open the footswitch again to repeat dispensing (see section [7.10](#)).
- 3) When the drive is running, press STOP key to stop the drive anytime when necessary.

7.8 Logic Level Control Mode

On this mode, use logic level signal to control start and stop. Use keypad to change speed.

- 1) Switch the power off. Wire the DB15 connector as shown on [Figure 15](#) or [Figure 16](#), and connect it to the DB15 port on the rear of the pump.

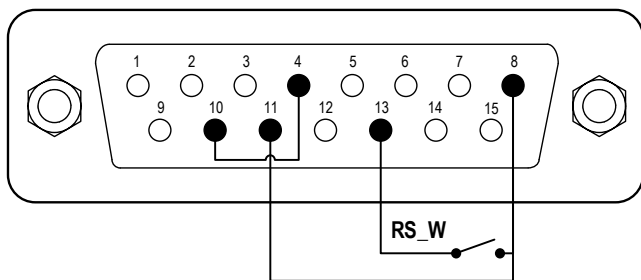

Figure 15. Logic Level Control with Internal 12V Power Source

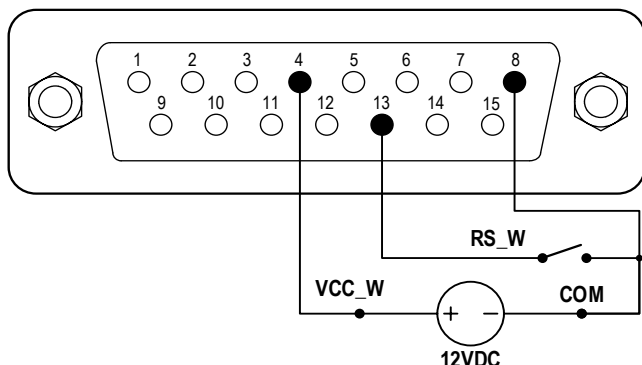
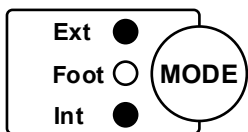

Figure 16. Logic Level Control with External 12V Power Source

2) Turn on the power switch. The display will be on.



3) Press MODE key to change the mode to Logic Level Control Mode.

4) Press UP or DOWN key to set the speed.

5) When RS_W switch is closed, the drive will be running; when RS_W switch is open, the drive will stop.

Note: Use this mode to work with a TIME DISPENSE CONTROLLER.

7.9 Communication Mode

The RS485 interface supports standard MODBUS protocol. Pump can communicate with external device via the communication port. Please refer to the [Communication Instruction Manual](#) for the parameters and supported commands.

1) When the power is off, wire the DB15 connector as shown on [Figure 17](#) or [Figure 18](#) and connect it to the DB15 port on the rear

of the pump. External DC power source is recommend to avoid electrical interference.

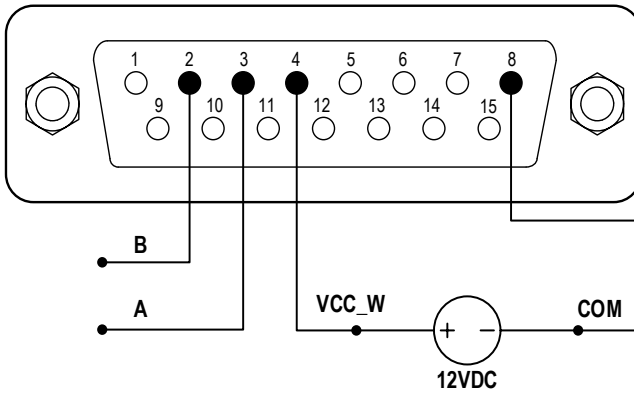

Figure 17. RS485 MODBUS Wiring with External 12V Power Source

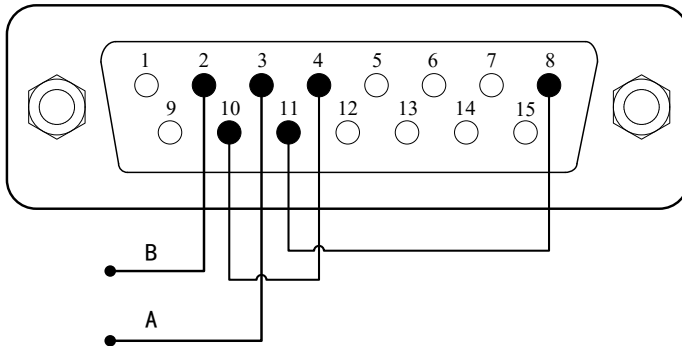

Figure 18. RS485 MODBUS Wiring with Internal 12V Power Source

- 2) Turn on the power switch. The LED display will be on.
- 3) Press MODE key to change the mode to Internal Control Mode or Time Dispense Mode.
- 4) Control pump with communication interface.
- 5) Press the STOP key to stop the drive anytime.

7.10 Footswitch Control

- 1) Switch the power off. Wire the DB15 connector as shown on [Figure 19](#) or [Figure 20](#), and connect it to the DB15 port on the rear

of the pump.

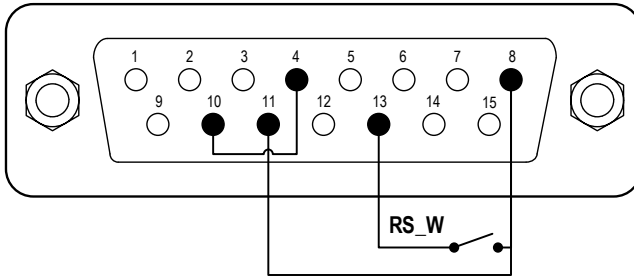

Figure 19. Footswitch with internal 12V Power Source

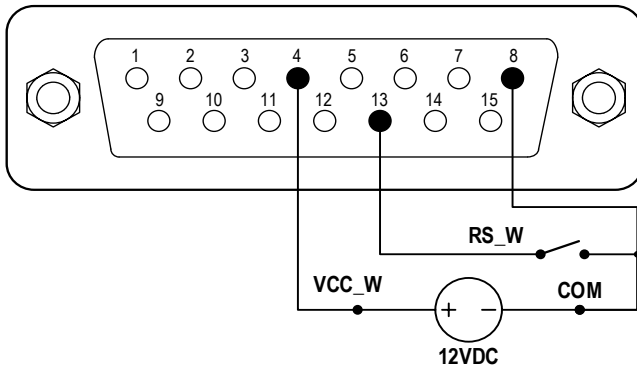

Figure 20. Footswitch with External 12V Power Source

- 2) Turn on the power switch. The LED display will be on.
 - 3) Press MODE key to change the working mode.
- On Internal Control Mode, close then open the switch RS_W to start the drive; close then open the switch again to stop the drive.
 - On Time Dispense Mode, close then open the switch RS_W to dispense one dose. Close then open the switch again to repeat dispensing.
 - On Logic Level Control Mode, close the switch RS_W to start the drive; open the switch to stop the drive.

8 Maintenance

8.1 Warranty

The product comes with one-year labor and parts warranty. The limited warranty does not cover any damage that is caused by improper usage and handling.

8.2 Regular Maintenance

- 1) Always check the tubing and connections to make sure there is no leakage.
- 2) Do not cover the fan on the rear of the pump.
- 3) Keep pump head dry.
- 4) If a filter is used, check and replace it regularly.
- 5) Do not use chemical solvents to clean pump and pump head.

8.3 Malfunction Solutions

No	Malfunction	Description	Solution
1	Hardware	No display	<ol style="list-style-type: none"> 1. Check the power cord 2. Check the fuse. If it was blown, replace it with a 3A slow-blow fuse 3. Check the internal power cord connection inside the pump. 4. Check the wire connection between LED display board and main control board.
2	Hardware	Motor does not work	<ol style="list-style-type: none"> 1. Check the indicator of the driver board. 2. Check the wire connection between motor and driver board. 3. Check the wire connection between the driver and the main board. 4. Check the power voltage for the pump.
3	Hardware	Motor is	<ol style="list-style-type: none"> 1. Check the wire connection between

Golander CT3000S Variable-Speed Gear Pump

		trembling	the motor and the driver board. 2. The motor is overloaded. Check the mechanical connection.
4	Hardware	Keypad does not work	1. Check the wire connection between keypad and the main board. 2. Check if the key is broken.
5	Hardware	External control does not work	1. Check the wiring of the connector. 2. Check if the external control power voltage is provided. 3. Check the connections of the external control board.
6	Hardware	RS485 com does not work	1. Check the wiring of the connector. 2. Check if the external control power voltage is provided. 3. Check the connections of the communication board.
7	Software	External control does not work	Check if pump is on External Control Mode.
9	Software	RS485 does not work right	1. Reset the address of the pump. 2. Check whether on the bus there are two pumps using the same address



If the problem can not be solved, please contact the manufacturer or distributor.

9 Dimensions

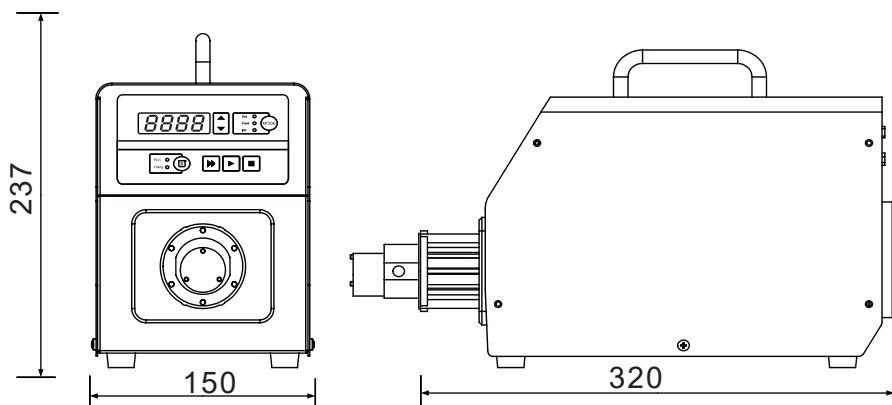
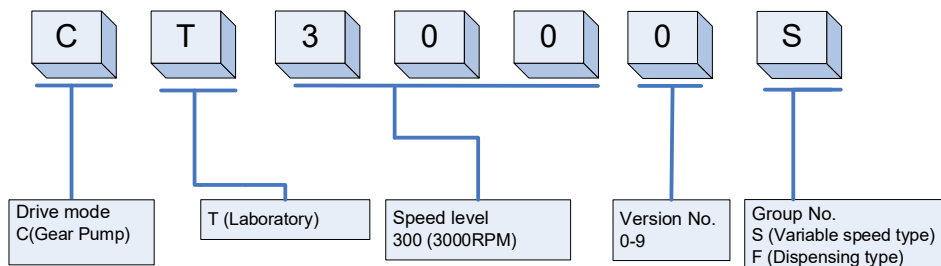

Figure 21. Dimensions (mm)

10 Naming Rule



11 Suitable Pump Heads

Pump Head	Max Output Pressure	Flow Range (mL/min)	Liquid Temperature
MS204 (PEEK)	1.4MPa (203psi)	90-900	-45-120°C
MS209 (PEEK)	0.9MPa (131psi)	180-1800	-45-120°C
MS213 (PEEK)	0.8MPa (116psi)	270-2700	-45-120°C